

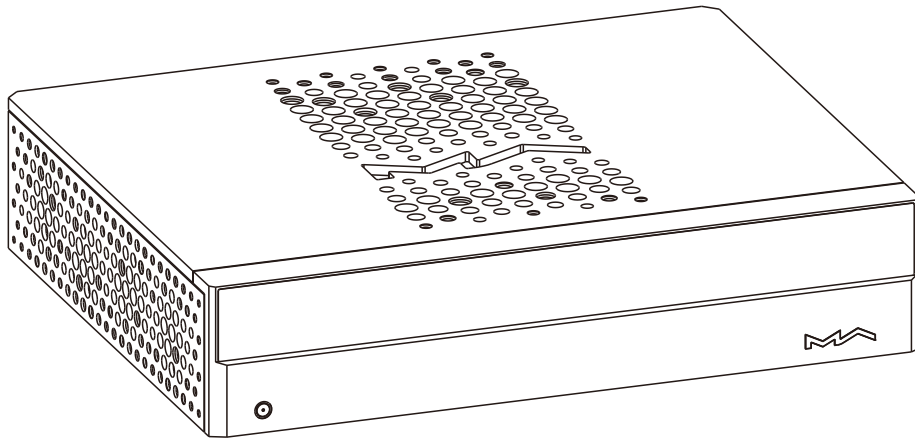

MP-1 User Manual

P r e a m p l i f i e r

| | |
|---|----|
| Packing list | 01 |
| Parts and names | 02 |
| Front | 02 |
| Rear | 03 |
| Settings | 04 |
| Channel balance | 04 |
| Input level adjustment | 04 |
| Default start volume | 04 |
| Remote control & address code | 04 |
| Programmable button | 05 |
| Brightness settings | 05 |
| Auto dimmer | 05 |
| Language setting | 05 |
| Factory reset | 05 |
| Product info | 05 |
| Appendix | |
| Audio specifications | 06 |
| Trigger | 06 |
| Power specs | 06 |
| Weight & size | 06 |



Product

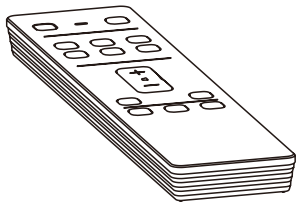

Remote control
(RM4C)

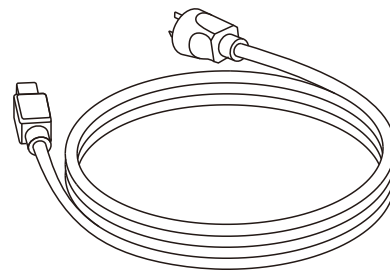

Power cable

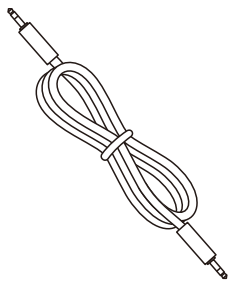

Trigger cable



User manual & warranty card

Front

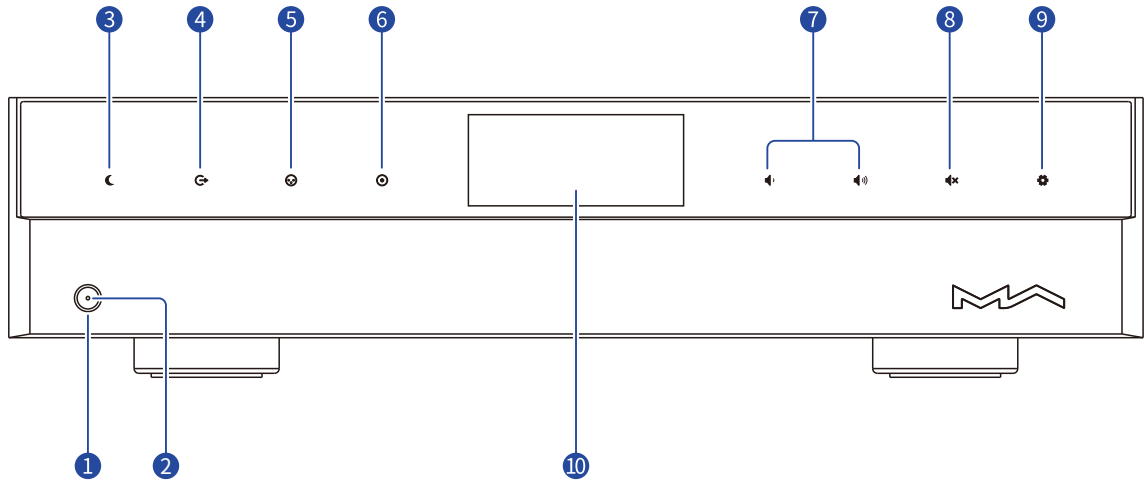

1 Power on/Standby

After connecting to power supply, press this button to power on the unit. Hold it for 1 second to let the device enter standby.

2 LED indicator

The LED indicator will go off when the device is standby. It flashes when the device is delayed starting, and will keep lit up after the device is started.

3 Touch button for Dimmer

Enable or disable Dimmer mode.

4 Touch button for output selection

Use this button to select among five output modes.

XLR-A: Balanced output A

XLR-B: Balanced output B

XLR: Balanced output A & B work simultaneously.

RCA: Single-ended output

ALL: All the output ports work simultaneously.

5 Touch button for XLR input

Use this button to select among three pairs of XLR inputs.

6 Touch button for RCA input

Use this button to select among three pairs of RCA inputs.

7 Touch button for volume up and down

Single touches change volume step by step, hold the button to change volume rapidly.

8 Touch button for mute and unmute

Use this button to mute and unmute.

9 Touch button for settings menu

Enter the settings menu by touching this button.

10 Display

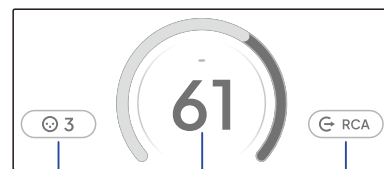

Input channel Volume level Output channel

Wear

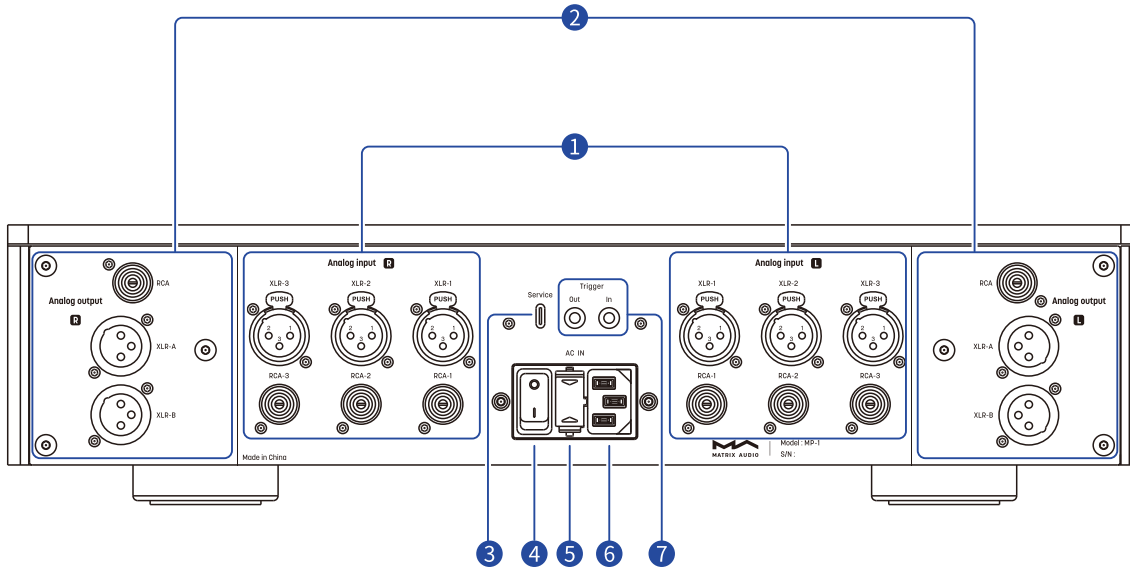

- 1 Analog input**
There are three pairs of RCA and three pairs of XLR inputs.
- 2 Analog output**
There is one pair of RCA outputs and two pairs of XLR outputs.
- 3 USB Type-C**
For firmware update.
- 4 Power switch**
If you need the device to be turned off completely, please turn off this switch. Otherwise, there is still about 1W power consumption in standby mode.
- 5 Fuse holder**
Please use a 5*20mm time-delay fuse.
- 6 Power input**
Please use a power cable which includes an earth wire and ensure you have a reliable earth wire connection. Otherwise, the casing of the device may have a slightly charged touch.
- 7 Trigger input/output**
Connect to audio devices with trigger ports through a $\varnothing 3.5$ mm mono plug cables, to achieve a linkage control between the MP-1 and other devices. The trigger output provides a 12V DC signal.

1. Balance adjust

Set the balance of left and right channels. Every step changes 0.5dB, the maximum adjustment per channel is 3dB.

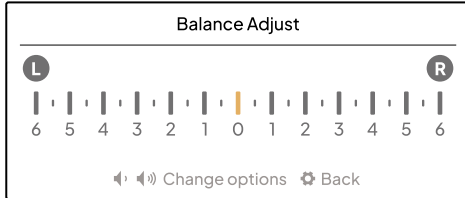

2. Input level adjust

Set the level of every input channel, to achieve the level of different input channels to keep consistent. Every step changes 0.5dB, the maximum adjustment is 6dB.

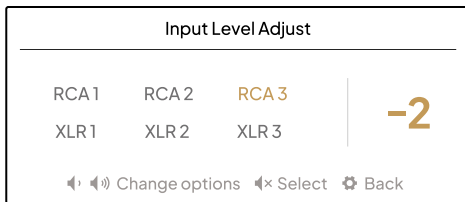

3. Output mode

Enable or disable some output modes. Output modes which are disabled will not be displayed in the output options, at least 1 output method must be selected.

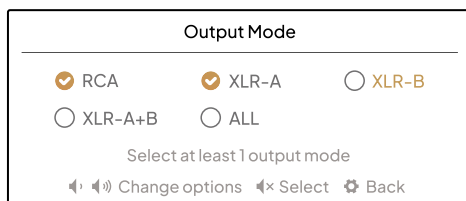

4. Volume control method

When the option "Independent volume" is selected, different volume values will be saved for every output channel.



5. Startup volume

Set the default volume when the device is turned on. The device can remember the volume before it was shut down or set to any volume between 1-60.

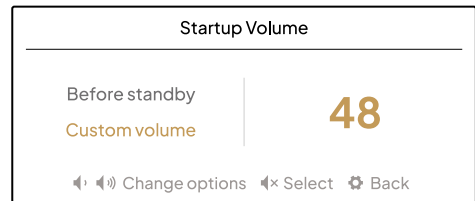
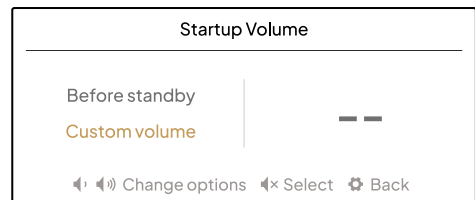

6. Remote control

Enable or disable IR remote control functionality. If there are multiple Matrix Audio devices that work at the same time, you can set the address code of the IR remote control to avoid misoperation.

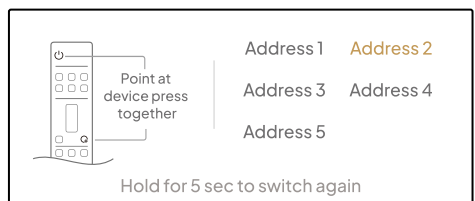
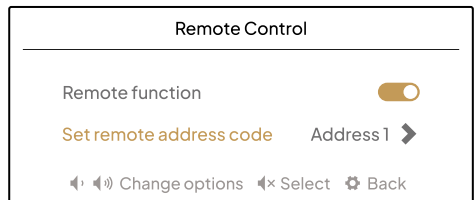

7. Programmable button

Set the functionality of programmable button on the IR remote control. They can be defined as a specific input channel or a volume level.

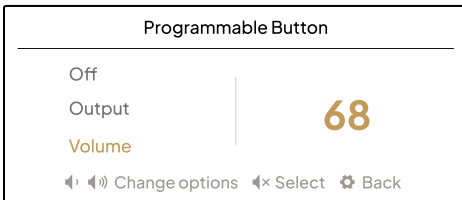
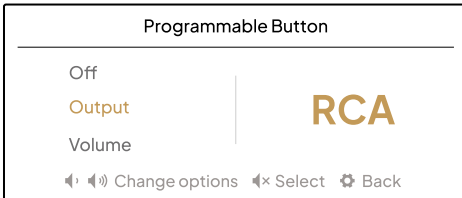

8. Backlight brightness

Set the brightness of the display and the touch buttons.

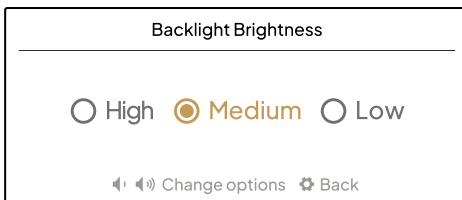

9. Auto dimmer

Enable or disable the device automatically enters dimmer mode when there is no operation. When this option is set to "Off", the device will still enter dimmer mode by pressing the Dimmer button on the IR remote or the touch button on the device.

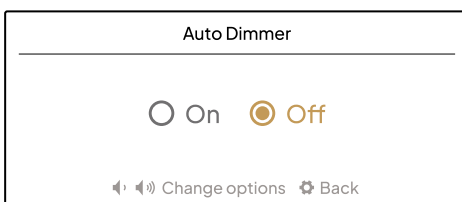

10. Language

Select your preferred language for the user interface. Chinese and English are available.



11. Load default

Reset all the settings to default.

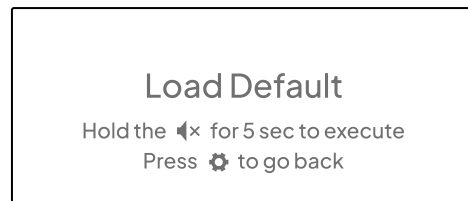

12. Product info

View the basic information of the device.



Audio Specifications

| | XLR | RCA |
|----------------------|--|--|
| Input Impedance | 40kΩ | 20kΩ |
| Output Impedance | 40Ω | 20Ω |
| Maximum Input Level | 9Vrms | 4.5Vrms |
| Maximum Output Level | 36Vrms | 18Vrms |
| Frequency Response | 20-20kHz ±0.1 250kHz @-3dB | |
| Dynamic Range Output | 129dB@A-weighting 125dB@Unweighting | 125dB@A-weighting 120dB@Unweighting |
| THD+N Output | <0.00015%@A-weighting <0.00020%@Unweighting | <0.00040%@A-weighting <0.00040%@Unweighting |
| Crosstalk Output | -140dB | -130dB |
| Gain | +12dB | |
| Volume Steps | 100 | |

Weight & size

Weight: 15.7kg (34.6 pounds)
 Size: Width: 430 mm (16.93 inches)
 Depth: 349 mm (13.74 inches)
 Height: 106 mm (4.17 inches)

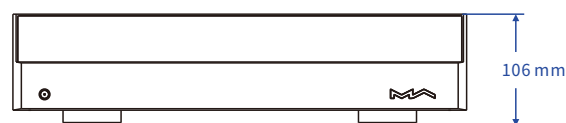
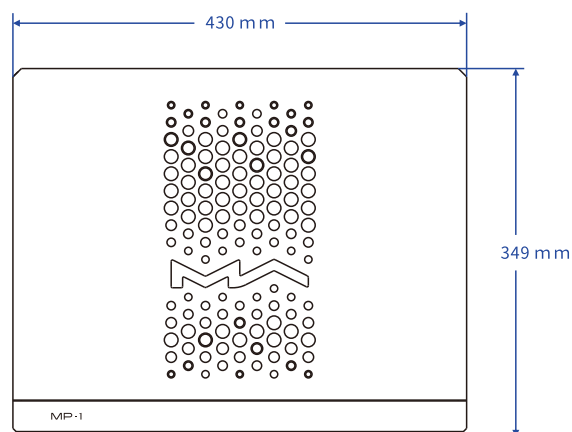

Trigger

Trigger In: DC 6-12V <10mA
 Trigger Out: DC 12V/50mA MAX

Power Specs

Power Voltage: AC 100V-120V 50/60Hz or AC 220V-240V 50/60Hz
 factory-fixed
 Standby Power Consumption: <1W
 Maximum Power Consumption: <70W

* For improvement purpose, specifications subject to changes without prior notice.

- This product is for indoor use only.
- For full ventilation, it is recommended to reserve a space of larger than 5 cm around the device.
- Do not cover the air vents with stuffs such as papers, tablecloths, and curtains to obstruct ventilation.
- Do not place stuff with flame, such as lighted candles, on the device.
- If the device is used in tropical areas, please be careful to prevent insects from entering the unit through the air vents.
- The device must not be subject to water droplets or splashes. Please do not place stuffs filled with liquids such as vases and cups on or near the device.



西安矩阵电子科技有限公司
Matrix Electronic Technology Co., LTD

🌐 matrix-digi.com

☎ +86-29-86211122

📍 陕西省西安市经济技术开发区明光路58号龙腾半导体产业园B栋206室
Room 206 Block B, #58 Mingguang Road Xi'an, Shaanxi

PGYB001V1.0